

RS **STANDARD**[®]
Composite Utility Poles

Hardware Guide (USA)





RS Technologies

www.RStandard.com

Email info@grouprsi.com
Toll Free +1 877 219 8002
Phone +1 403 219 8000
Fax +1 403 219 8001

2421 - 37th Avenue NE, Suite 400
Calgary, AB T2E 6Y7



Hardware Guide
Table of Contents

1.0	Introduction to the RStandard Hardware Guidelines	2
2.0	Basic Characteristic Strengths	3
2.1	Pull Through	3
2.2	Vertical Bearing	3
2.3	Bolt Torque	3
3.0	General Recommendations and Best Practices	4
3.1	General Recommendations	4
3.2	Hardware Fit	4
3.3	Hole Spacing Conventions	5
4.0	Specific Hardware Ratings	6
4.1	Guying Fittings	6
4.1.1	2 Bolt Guy Fittings	6
4.1.2	3 Bolt Guy Fittings	7
4.2	X-Brace Fittings	8
4.2.1	2 Bolt X-Brace Fitting	8
4.2.2	3 Bolt X-Brace Fitting	9

1.0 Introduction to the RStandard® Hardware Guidelines

RStandard composite utility poles are constructed from a fiber reinforced polymer (FRP) material system using polyurethane resin. The use of this composite material, combined with a modular design, provides communication, transmission and distribution utility poles of a lower overall weight, enhanced strength and longer lifespan than traditional pole alternatives. This hardware guide has been developed to outline recommendations, best practices and basic loading scenarios that can be used to select appropriate hardware for use with the RStandard poles. Any questions related to this guide or the application of hardware can be directed to the RS Technologies' Customer Service Department.

2.0 Basic Characteristic Strengths

This section provides the recommended design loads for basic hardware configurations. The design loads below do not take into account hardware geometry, fit, or other factors that can affect load capacity. These numbers should only be used as a guideline for general hardware consideration. Questions related to the application of specific hardware should be directed to RS Technologies.

The loading scenarios below are intended to be used with factored National Electric Safety Code (NESC) Grade B or Grade C loads. Hardware applications for extreme loadings conditions, such as extreme ice or wind loads, should be analyzed on a case-by-case basis. For assistance in the selection of appropriate hardware for these applications, please contact RS Technologies.

2.1 Recommended Horizontal Pull Through Design Load

- Pull through of a 4 in. x 4 in. x ¼ in. [102 mm x 102 mm x 6 mm] square curved galvanized steel washer, pulled with a ¾ in. [19 mm] A325 steel bolt.
- Design Load = 5,000 lbf [22 kN]
- Pull through of two 4 in. x 4 in. x ¼ in. [102 mm x 102 mm x 6 mm] square curved galvanized steel washers, pulled uniformly by two ¾ in. [19 mm] A325 steel bolts spaced 6 in. [152 mm] apart.
- Design Load = 7,000 lbf [32 kN]

2.2 Recommended Vertical Hole Bearing Design Load

- Vertical loading of one pole wall with a ¾ in. [19 mm] A325 steel bolt.
- Design Load (for a ¾" [19 mm] diameter bolt) = 4,000 lbf [18 kN]

2.3 Bolt Torque

Proper bolt torque is essential to achieving a strong, durable bolted connection. For ¾ in. [19 mm] UNC galvanized bolts, RS recommends a through-bolt torque of between 30 to 50 lb-ft. [40 to 68 N-m]. Excessive torque may lead to high pole wall deflections and unnecessary stress. Recommended torques will change accordingly with bolt diameter, thread form and surface finish.

3.0 General Recommendations and Best Practices

3.1 General Hardware Recommendations

In general, conventional utility hardware can be used on the RStandard® pole. In some cases, substitutions or alterations need to be made to ensure hardware fit or compatibility. The following recommendations reflect common best practices that can be used in conjunction with the verification of hardware design loads. Any questions on hardware application or suitability can be directed to the RS Customer Service department.

- **Curved washers**

Curved washers work very well to spread load and reduce localized stress concentrations at attachment points. It is recommended that all bolted connections to RStandard poles utilize curved washers (at least ¼ in. [6 mm] thick) to help spread the load and maximize the durability of the connection. As a minimum general practice 4 in. x 4 in. [102 mm x 102 mm] curved washers should be used on all connections wherever possible.

- **Banded Solutions**

Banded or strapped hardware mounts (utilizing metal strapping to strap around the circumference of the pole) work very well with RStandard poles. The natural consistent taper of the RStandard pole helps to minimize settling of banded mounts. Banded solutions typically work very well to spread load over a larger area and minimize stress concentrations from bolts and other hardware.

Note: Pole bands with through bolts are not recommended.

- **Self-tapping screws**

In any situation where nails or staples would be used on a wood pole, self-tapping screws can be used on RStandard poles. These screws are very easy to use and hold well in composite material.

3.2 Hardware Fit

Proper hardware fit is critical for long term, durable connections to the RStandard pole. Hardware should conform to the surface of the pole without making any sharp or knife-edge contact. Cleated or studded hardware commonly used on wood poles should not be used on the RStandard pole (see Figure 6). Alternate hardware solutions can be found for these situations.

To account for the gradual taper of RStandard poles, different hardware curvatures may be required depending on the location of the hardware to be mounted (see Figure 7 and Figure 8). Any questions related to hardware fit can be directed to the RS Customer Service department.



Figure 6: Example cleated hardware not to be used with RStandard poles.



Figure 7: Correct hardware curvature



Figure 8: Incorrect hardware curvature

3.3 Hole Spacing Conventions

Ensuring appropriate hole size and spacing is important in achieving a strong, durable connection to the pole wall. Below are general guidelines for hole size and spacing which should be maintained (see Figure 9).

- Minimum Hole Spacing: Center-to-center distance of any two holes should be a minimum of $6D$ (six times), where D is the diameter of larger of the two holes.
- Minimum Edge Distance: A minimum distance of $5D$ (five times), where D is the hole diameter, should be maintained from the edge of the module to the center of the hole.
- Maximum Hole Size: Hole diameters larger than $2.5T$, where T is wall thickness (approx. 1.25 inches [32 mm] diameter), are not recommended.

Contact RS Technologies to resolve any hole sizes or locations that may not meet these guidelines.

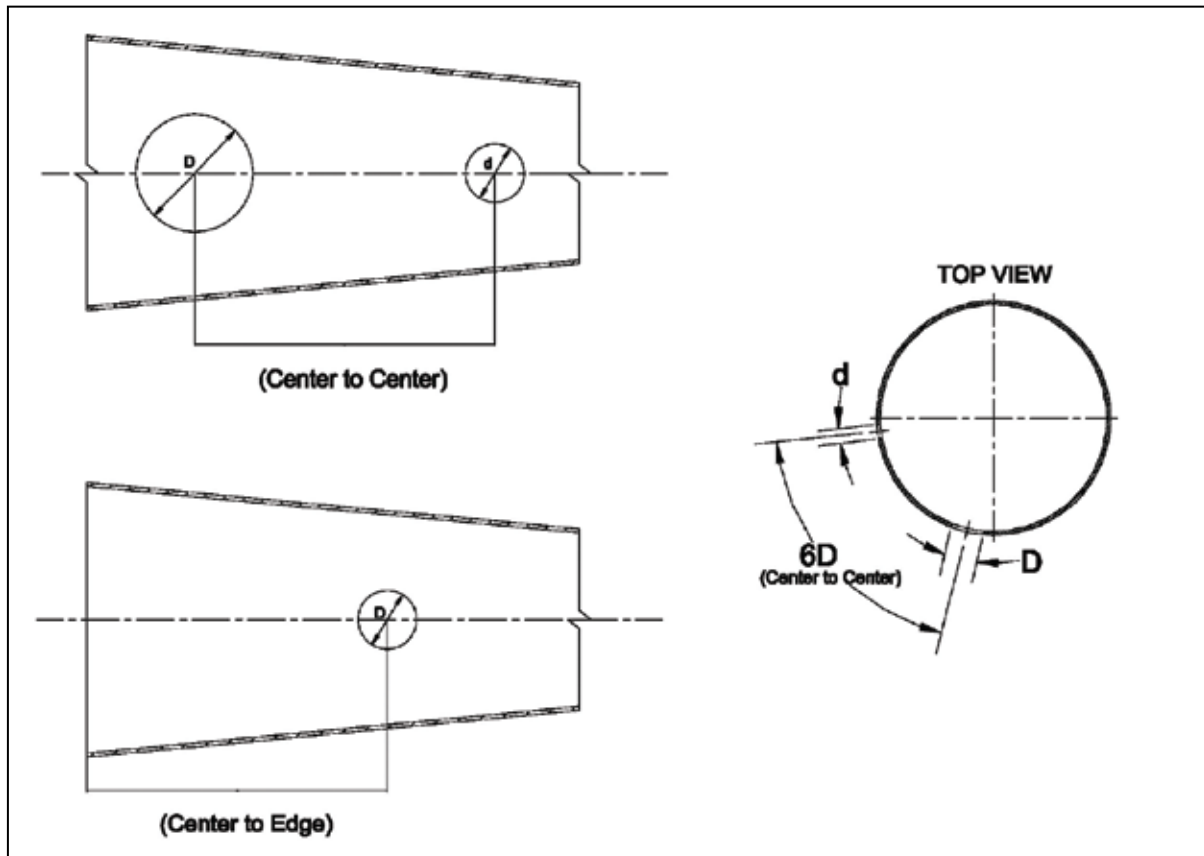

Figure 9: Minimum Hole Spacing Conventions.

4.0 Specific Hardware Ratings

This section provides recommended load ratings for specific attachment types. These ratings were attained through RS's ongoing program of physical testing.

4.1 Guy Fittings

Simple 2-bolt and 3-bolt guying assemblies are shown below (see Figure 10 and Figure 11). These are provided for initial hardware planning only. To confirm the viability of other solutions contact RS Technologies.

4.1.1 2 Bolt Guying Setup

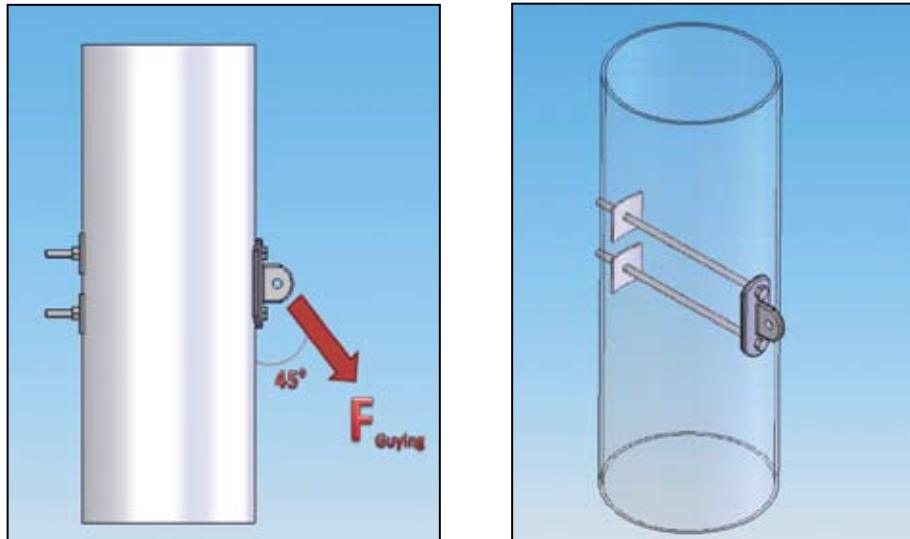

Figure 10: Example 2 bolt guying setup.

Guying Tee:	Hughes Brothers 2817R4.5-13-15
Backing Hardware:	4 in. x 4 in. x ¼ in. thick [102mm x 102mm x 6mm thick] curved square washers (galvanized steel)
Number of Bolts:	2 Bolt Diameter: ¾ in. [19 mm]
Hole Diameter:	7/8 in. [22 mm]
Bolt Spacing:	6 in. [152 mm]
Bolt torque:	30 lb.-ft. [40 N-m]

Maximum guying force, F_{Guying} @ 45° = 7,500 lbf [33.4 kN]

4.1.2 3 Bolt Guy Fittings

This 3-bolt guying setup uses the same guying tee as the 2-bolt set-up but utilizes a front side extender plate to add a third bolt. In addition, a C-channel spreader plate is used on the back wall of the pole to spread load more effectively.

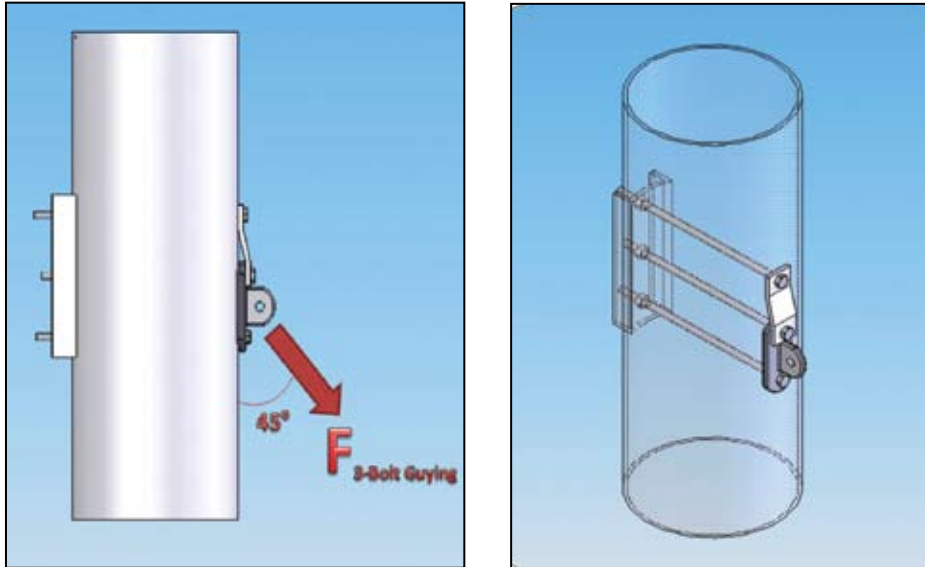

Figure 11: Example 3 bolt guying setup.

Guying Tee:	Hughes Brothers 2817R4.5-13-15 with ½ in. [13mm] thick extender plate
Backing Hardware:	C-Channel Spreader Plate - ½ in. [13 mm] thick, 16 in. [406 mm] long
Number of Bolts:	3
Bolt Diameter:	¾ in. [19 mm]
Hole Diameter:	7/8 in. [22 mm]
Bolt Spacing:	6 in. [152 mm] between all bolts
Bolt Torque:	30 lb.-ft. [40 N-m]

Maximum guying load, F_{Guying} @ 45° = 12,500 lbf [55.6 kN]

4.2 X-Brace Fittings

Simple 2-bolt and 3-bolt X-Brace assemblies are shown below (see Figure 12 and Figure 13). These are provided for initial hardware planning only. To confirm the viability of other solutions contact RS Technologies.

4.2.1 2 Bolt X-Brace Fitting

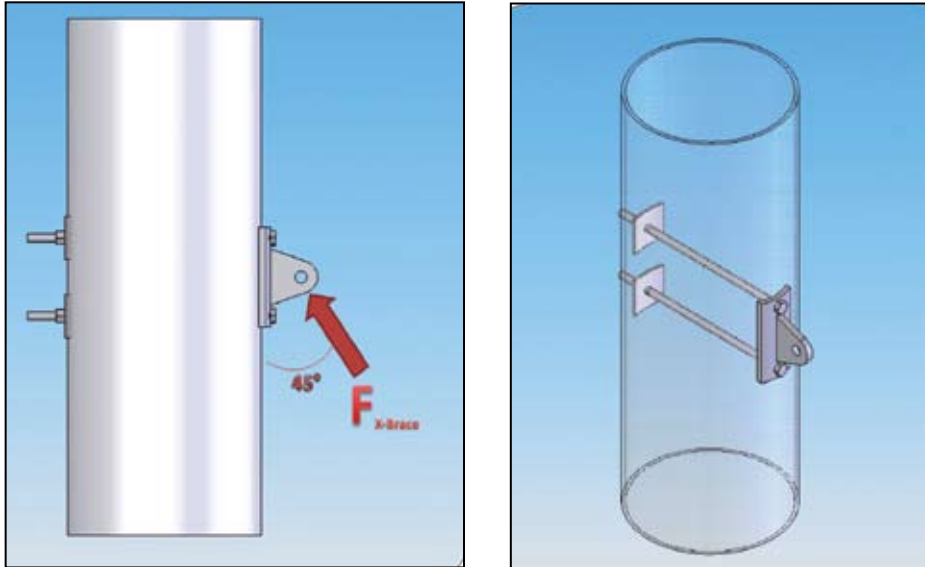

Figure 12: Example 2 bolt x-brace fitting.

X-Brace Tee:	Geotek X-Brace Tee
Backing Hardware:	4 in. x 4 in. x ¼ in. thick [102 mm x 102 mm x 6 mm thick] curved square washers (galvanized steel)
Number of Bolts:	2
Bolt Diameter:	¾ in. [19 mm]
Hole Diameter:	7/8 in. [22 mm]
Bolt Spacing:	7.25 in. [184 mm]
Bolt Torque:	30 lb.-ft. [40 N-m]

Maximum X-Brace load, $F_{X-Brace}$ @ 45° = 8,500 lbf [37.8 kN]

4.2.2 3 Bolt X-Brace Fitting

This 3-bolt X-bracing setup uses the same tee as the 2-bolt set-up but utilizes a C-channel spreader plate to spread load more effectively and add a third bolt.

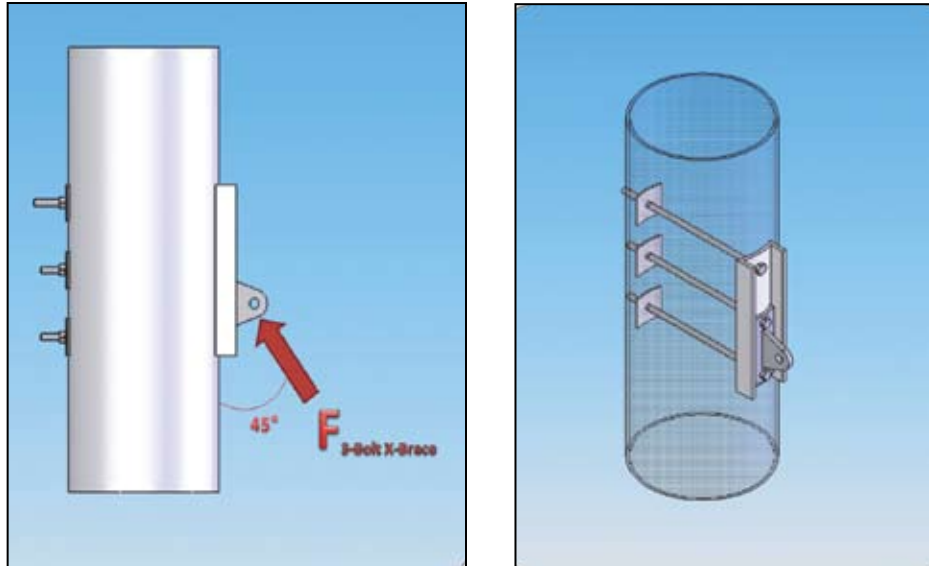

Figure 13: Example 3 bolt x-brace fitting.

X-Brace Tee:	Geotek X-Brace Tee with C-Channel spreader plate - ½ in. [13 mm] thick, 18.5 in. [470 mm] long
Backing Hardware:	4 in. x 4 in. x ¼ in. thick [102 mm x 102 mm x 6 mm thick] curved square washers (galvanized steel)
Number of Bolts:	3
Bolt Diameter:	¾ in. [19 mm]
Hole Diameter:	7/8 in. [22 mm]
Bolt Spacing:	7.25 in. [184 mm] between all bolts
Bolt Torque:	30 lb.-ft. [40 N-m]

Maximum X-Brace load, $F_{X-Brace}$ @ 45° = 21,250 lbf [94.5 kN]

Note: The above hardware scenarios are for initial planning and guidance purposes only. The customer is responsible for validating any design based on these guidelines. For hardware recommendations to suit specific load cases, please contact RS Customer Service.



www.RStandard.com

Email info@grouprsi.com
Toll Free +1 877 219 8002
Phone +1 403 219 8000
Fax +1 403 219 8001

2421 - 37th Avenue NE, Suite 400
Calgary, AB T2E 6Y7

For more information on this product contact:



"RStandard" and "Infrastructure For Life" are registered trademarks of Resin Systems Inc.
*Disclaimer - The information contained herein is offered only as a guide for RStandard poles and has been prepared in good faith by technically knowledgeable personnel. This sheet is for information only and could be modified without notice. Printed in Canada.

TSX:RS



RSHG V2.2